



C-COM DISCLAIMER

Legal Notice:

Certain written and oral statements included in this presentation may constitute “forward-looking information” reflecting the current expectations of C-COM Satellite Systems Inc. (“C-COM”). For example, statements about market opportunities, C-COM’s ability to capitalize on such opportunities, new products, features and functionality, potential growth rates, extrapolated revenues and other statements about any future expectation or event, are all forward-looking information. This information reflects C-COM’s current beliefs with respect to future events and is based on information currently available to management. Forward-looking information involves significant known and unknown risks, uncertainties and assumptions. Many factors could cause actual results, performance or events to be materially different from those implied or expressed by forward-looking information in this presentation. Should one or more of these risks or uncertainties materialize, or should assumptions underlying the forward-looking information prove incorrect, actual results, performance or events could vary materially from those expressed by forward-looking information in this presentation. Although forward-looking information contained in this presentation is based upon what C-COM believes to be reasonable assumptions, C-COM cannot provide assurances that actual results, performance or events will be consistent with the forward-looking information in this presentation and cautions that undue reliance should not be placed on the forward-looking information. This presentation was originally given on May 4th, 2022. The forward-looking information is given as of the date on which this presentation was first given and may be out of date or proven inaccurate by the time this presentation is viewed. C-COM does not assume any obligation to update or revise this presentation to reflect new events or circumstances, except as required by law. Viewers should view the totality of C-COM’s public disclosure available at www.SEDAR.com including C-COM’s most recent MD&A located at www.SEDAR.com which describes risk factors associated with C-COM’s business and an investment in C-COM. Those risk factors are incorporated into this presentation by reference.

Nothing in this presentation is intended to be an offer to sell or a solicitation for offers to buy securities of C-COM in any jurisdiction. C-COM was not undertaking or contemplating a sale of securities or accepting offers to acquire securities from C-COM as of the date on which this presentation was first given.

C-COM – Pioneer in Mobile VSAT

- C-COM is an Ottawa-based technology company focused on research, development and design of fully motorized, auto-deploy, mobile satellite antenna products (iNetVu®).
- Established in 1997, C-COM is one of the largest Comm-On-The-Pause (COTP) mobile VSAT manufacturers in the world.
- Company is developing highly disruptive antenna technology (electronically steerable phased array).

Employees: 33
Exchange: TSXV: CMI and OTCQB: CYSNF
Dividend yield: 4.0% (Q3, 2024)



C-COM by the Numbers



- 11,000+:** iNetVu® commercial mobile VSAT systems sold
- 106:** Number of countries in which you will find iNetVu®
- 600+:** Active dealer partners worldwide
- 41:** Models available of the iNetVu® auto-acquire, motorized antenna
- 10:** Modem manufacturers PLUG & PLAY Integrated with iNetVu® (35 different modem models)
- 12:** Sizes of antenna available (60cm, 74cm, 75cm, 80cm, 98cm, 1.0m, 1.2m, 1.3m, 1.5m, 1.8m and 2.4m)
- 4:** Formats of antenna (Driveaway, Flyaway, Manpack, Fixed Motorized)
- 4:** Bands of antenna available (Ka, Ku, C & X band)
- \$25.2 million:** Working Capital (as of May 2024)
- \$25.5 million:** Shareholder Dividends Paid (as of May 2024)
- 49:** Consecutive Quarterly Dividends
- \$0:** Debt

Note: As of May 2024. All figures in \$CAD



Commercial Markets Using Mobile SATCOM

- Government
- Military
- Emergency Response
- Disaster Recovery
- Blue Light Vehicles
- Oil & Gas
- Telecom Companies
- Banks
- Broadcasters
- Hospitals
- Schools
- Mining
- Events



Where terrestrial infrastructure is **LIMITED**, **DISRUPTED**, or **NON-EXISTENT**, Broadband Internet via Satellite is the **ONLY** option

Worldwide Deployment

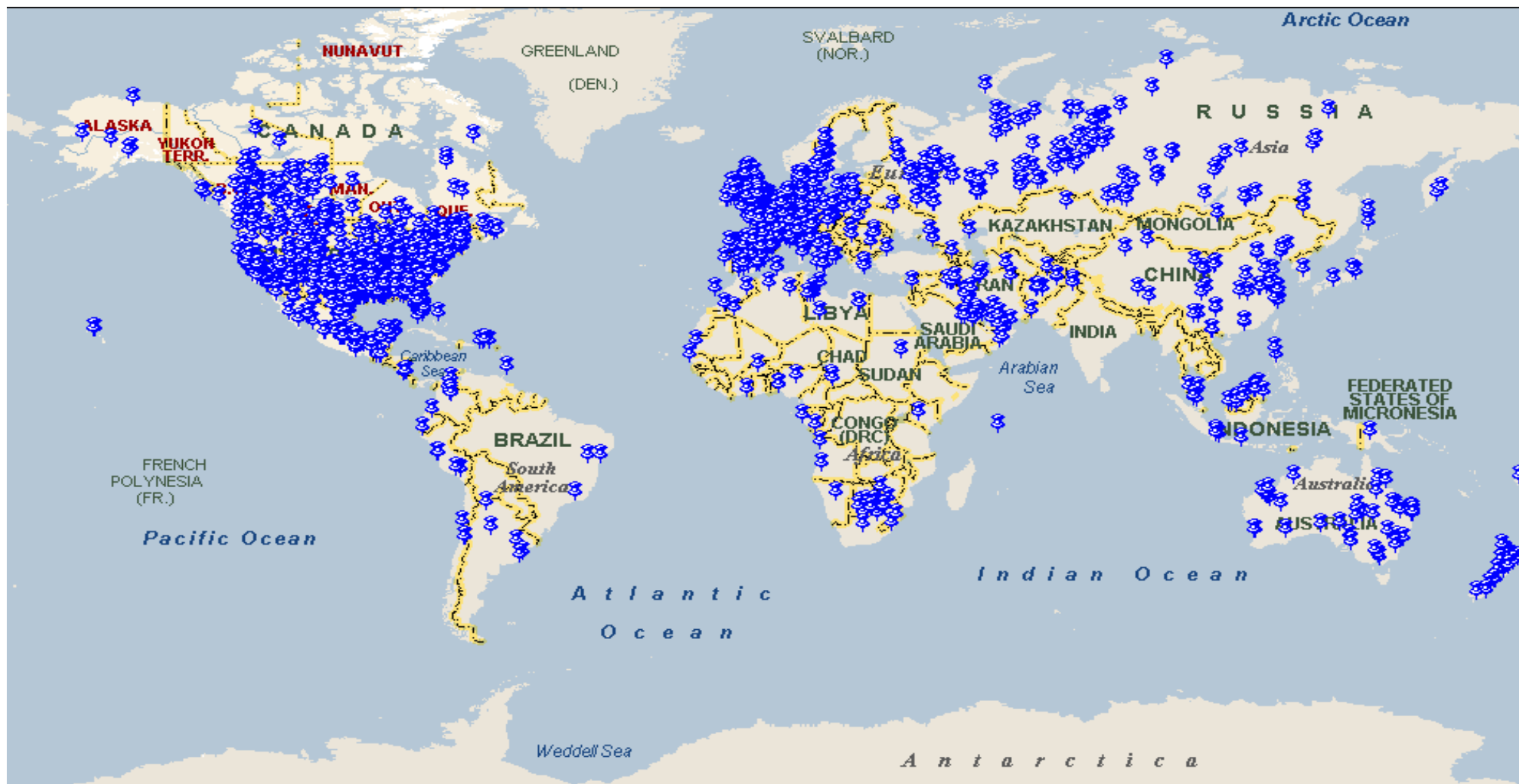

iNetVu® Platforms (74cm – 240cm)

Ka Ku C X



DriveAways



Ka-74/G/H



Ka-75VP/KASAT



980+/982



Ka-98G/V/HJUP



Ka-1200+G



Ka-1200+V/H



1200+



1501+



1801



FlyAways



FLY-74/G/H



FLY-75V



FLY-981



FLY-98G/V/H



ACFLY-1200



FLY-1202



FLY-1202G/V/H



FLY-1801



MP-60/80/100/130

Manpack



FMA'S (Fixed Motorized Antenna)



FMA-121



FMA-121Ka



FMA-180+



FMA-241

iNetVu® Controllers

The iNetVu® Controller Series



7715 (19" Rackmount)

- Simple stand-alone one touch operation to find satellite and stow antenna
- Typical satellite acquisition time in less than 2 minutes
- Ideal for applications that require a quick, simple setup and reliable connection
- Supports DVB-S1 and DVB-S2/ACM frequencies (modem independent)
- Optimal, high-precision antenna pointing, supports inclined orbit satellites
- Remote access and operation via Network, Web and other Interfaces
- Built-in motion and movement protection for safety
- Internal DVB-S2X receiver for modem independence
- Integrated with 20+ modems (Hughes, iDirect, Newtec, Gilat, Viasat, Comtech, etc.)
- 7 methods of finding satellite



*7750 Flyaway
(Outdoors)*



*8050 Manpack
(Outdoors)*

74cm Auto-Acquire Ka-band DriveAway (Eutelsat, Hughes & Gilat)

Ka

NEW
GEN

iNetVu® Ka-74X



Ka-74G



- G – Eutelsat/Konnect Approved; also compliant with Gilat (SkyEdge) Ka services

Ka-74H-JUP



HUGHES

- H-JUP- Hughes Jupiter modems. The Ka-74HJup is suitable to operate with HNS Jupiter Networks

iNetVu®7715Controller

98cm Auto-Acquire Ka-band DriveAway (Hughes, ViaSat, Avanti & Gilat)



NEW
GEN

iNetVu® Ka-98X

(G/V/H/H-JUP)



iNetVu®7710Controller

Ka-98G



avanti Approved Compatibility



Ka-98V



eutelsat
type approved for KA-SAT

ViaSat

Ka-98H



avanti Approved Compatibility

YahClick
SEARCH BY NAME

Ka-98HJUP



HUGHES

- G - Avanti Approved; Thor7 Type Approved; also compliant with Gilat (SkyEdge) Ka services
- V - Exede by ViaSat / KA-SAT satellites using ViaSat Broadband Modems. Auto beam select is available on the KA-SAT Tooway service.
- H - Hughes Ka-band modems. The Ka-98H is suitable to operate over the Yahsat Yahclick network, and will be adapted as more networks become available.
- H-JUP- Hughes Jupiter modems. The Ka-98HJup is suitable to operate with HNS Jupiter (NA)⁽¹⁾, YAHSAT (MENA)⁽¹⁾ and Avanti⁽¹⁾
- Pod option available

⁽¹⁾Supported RadiosSpacewayor Jupiter. Please specify which radio being used when ordering.
<http://www.avantiplc.com/avanti-approved-compatibility>

New Generation 1.2 m Auto-Acquire Ku-band DriveAway



NEW
GEN

iNetVu® 1202



Ka-band or Ku-band

- Field Upgradable to Ka-Band
- Low Stow, high-precision antenna pointing, near zero backlash
- Excellent Cross-pol performance
- Based on Eutelsat approved Skyware 1.2m Antenna, Type 125
- Works on all Ku Supported Services
- Characterized with Eutelsat* and Intelsat Compliant
- Patented sleek aerodynamic form (Patent # D696649 & D696650)
- Optimal high-precision antenna pointing
- Wind deflector pod (optional)
- 2-piece thermoset-molded reflector (optional)

1.2 m Auto-Acquire FlyAway

iNetVu® FLY-1202



FLY-1202G



FLY-1202V

- 1.2m FlyAway Antenna
Designed for Ku and X Band
- Low cost, high precision
antenna pointing, near zero
backlash
- Setup less than 15 minutes
- Tool less, Captive H/W
fasteners
- Fits in 4 Transportable Cases,
under 35kg ea.
- Based on Eutelsat approved
1.2m Skyware antenna

iNetVu® Manpack

Ka

Ku

X

NEW
GEN

Manpack systems can be easily configured to provide quick access to satellite communications for any application that requires remote connectivity in a rugged environment.

Ideally suited for applications that require a quick, simple set-up; in vertical markets such as emergency response, disaster management, public safety, broadcast, media and more.



Simple to Assemble and Easy to Use

Manpack



Auto-Pointing System Option
Includes Onboard Controller

MP-60/80/100/130 - Manpack

- Complete satellite acquisition in seconds
- Super quiet operation, no noise
- IP 66 Rating of whole system
- Assembly in 4-5 minutes without tools
- High precision reflector petal can be interchanged among one system and over multiple systems
- Multiple bands support: Ku, Ka, X
- Supports manual operation with handwheels and indicators

iNetVu® Manpack - MIL

Ka

Ku

X

NEW
GEN



Manpack Deployment for Film Production in British Columbia



Manpack Deployment in Japan following Typhoon 19





Oil & Gas



FracTech - Texas, USA - 1200



ITC Global - Australia - FLY-1201



Diverselt - Perth, Australia - 1200



TC Communication - Australia 1200



Oil & Gas - Halliburton - 980



Libya - Hermes - 1200



Sinopec - China - 1200



BSC - Beijing - 1200



Satellite News Gathering



WebTVLive OTT by C2D.eu - RTC
Belgium Broadcaster - Ka-75V



DDish TV - Mongolia - 1201



Spar Woman's Day Race - Grintek -
Africa - Ka-98H



SNG - ViaSat - USA - Ka-75V



SNG - Newspotter - Eusatnet
(SatSpeed) Germany - Ka-75V



CCTV in China - Sichuan
Earthquake - 1200



SNG - ARY News - Pakistan - 1200



Elections in Angola - Grintek - 1200



Emergency Response



Excelerate - UK - 1200



Landslide Disaster
JSC Japan - 980



Police Command Vehicle
Altegosky - Russia - 1200



FireTruck - Xian - China - 1200



Fire Department - Japan - 1201



ER - Primetech - UK - Ka-75V



Disaster Recovery - Softbank - 980



Indonesia - 1200



TeleHealth



Telemedicine and Mobile Diagnostic Center Altegrosky - Russia - 1200



Mobile Health - Remote Comm LLC Midland, TX - 1200



Mobile Surgical Satellite Service New Zealand - 1800



Loma Linda University - USA - 1200



Mobile COVID Vaccination Clinic - Hughes - US - 1200



Mobile Health Care Services Siberia - 1200



Breast Screening - NZ - 980



Transnet Phelophepa Health Train Grintek - South Africa - 1200



Military



Polish Military - TTCom - 1800



Military - Russia - 1200 & 980



Russian Police Vehicle - 1200



Military - Russia - 1200



Military - 1200 transported on a Russian IL-76 Cargo Plane



Russian Military - Fly-1201



Military Forward Operations Base - USA FLY-1201 - Carolina Satellite



Vietnam Military Vehicle - 980



Telecom



Telecom – TFL – Fiji – 1200



Telecom – TFL – Fiji – 1200



Telecom - Numix -Broadband on Wheels - Malaysia- 1200



Telecom Malaysia Mobile Store Numix - 980



AT&T – UK - 1800



Telecom – China - 980



Telecom Malaysia - Numix - 1200



Telecom Malaysia - Numix -980



Mobile Office



Gov. pension programme Vox
Telecom – South Africa – Ka-98H



Peru – FLY-981



Telespazio – Demo – Germany- 981



Government - Mobile ID Vehicles
Argentina - Telespazio - 1200



Mobile Sight Services - UK
Primetech - 750



Mobile Office - Eskom
South Africa - 980



Mobile Tax Office - Grintek
South Africa - 980 - SARS



Youth Services - UK – Primetech -
Ka-75V

Mobile Banking



NTI Soluciones – Spain - 1200



South Africa
Grintek - 980



UK - Primetech - Ka-75V



Numix - Malaysia 981



Transportable ATM Container
New Zealand - Bay City - 980



Coris Bank International - 980



Germany - 1200



SATCOM Business Innovating Aggressively

The worldwide Satellite business is a \$286 billion market. Flat Panel Satellite Antennas represent a \$33 billion opportunity over the next decade.

Many big players, with very ambitious projects, are now getting involved:



OneWeb
(Eutelsat+Hughes+Bharti-India)
648 Satellites



Musk (SpaceX)
6000 microsats



Bezos (Amazon-Kuiper)
3,236 satellite constellation



Telesat Lightspeed
188



Boeing 132



Gates funding
Kymeta



Entering the GOLDEN AGE OF the SATELLITE BUSINESS?

O3B, SpaceX, Amazon, OneWeb, Inmarsat, Telesat, Viasat, Intelsat, Hughes, Kepler, Boeing, Eutelsat, AsiaSat, Yahsat and others have large-scale goals. All of these grand schemes require antenna design expertise. All require reliable & high precision ground station antennas. Can they be cost effective?

Low Cost Phased Array Antenna System for Ka-band Mobile SOTM

- C-COM Satellite Systems, in partnership with the University of Waterloo, is creating its first Phased Array Antenna (PAA).
- C-COM tested its Ka-band Phased Array modules using the company's **patented phase shifter technology** in 2020.
- **The proof-of-concept prototype has been successfully concluded by satellite tests in 2021.**
- The concept is based on modules that are small, but contain everything — the antenna, plus the electronic circuit, parts of the control circuitry, and local memory.

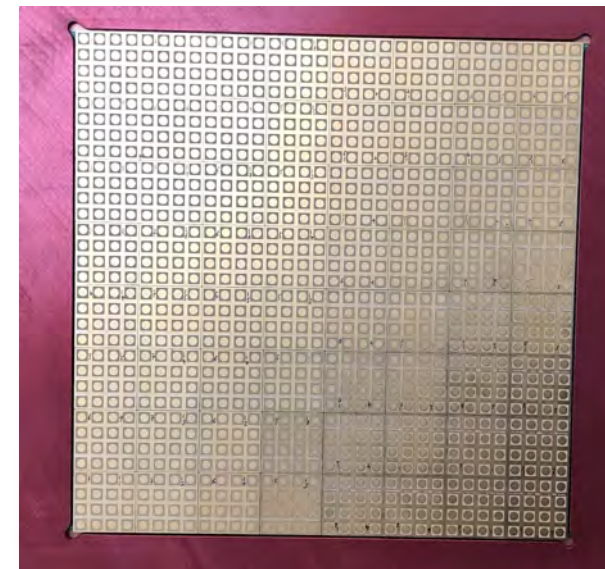
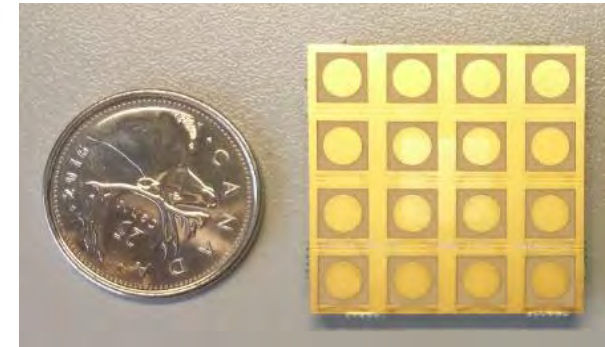

16x64 RX 4x4 Modules
(1024 Elements)

Advantages of Proposed Technology

INTELLIGENT CHIP BASED TECHNOLOGY

- System can have full control over each module
- Can perform electronic beam steering
- Can optimize the beam
- Can electronically scan 360 degrees
- **Scalable**
 - Gain can be increased by adding multiple modules
 - Allows for small building blocks which can be used to make any size of antenna;
- **Conformal**
 - Bends to fit various shaped surfaces

- **Dramatic cost reduction**
 - One antenna consists of several thousands chips, a few hundred antennas could reach a volume of millions of chips.
 - It will be easy to reach “economies of scale”, leading to significant cost savings.
 - Applicable to many vertical markets

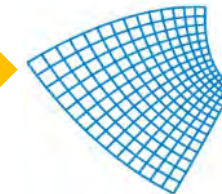
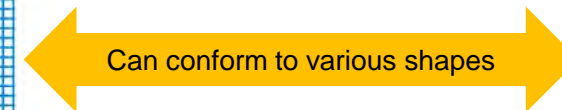
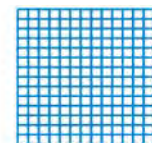
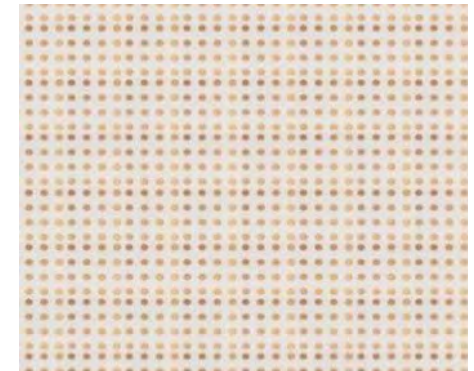
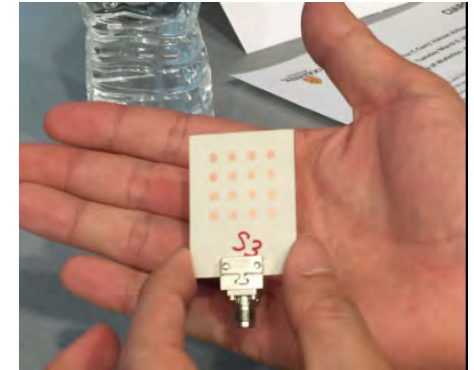

InsightAce Analytics's Flat Panel Antenna Market Research

Satellite Flat Panel Antenna Market Research Report

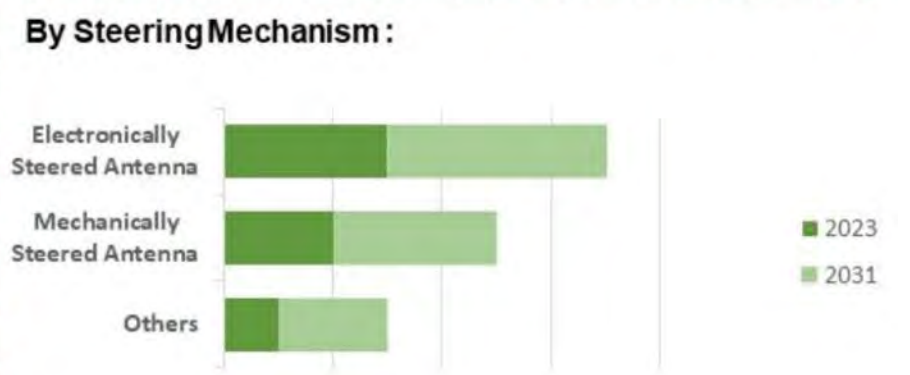
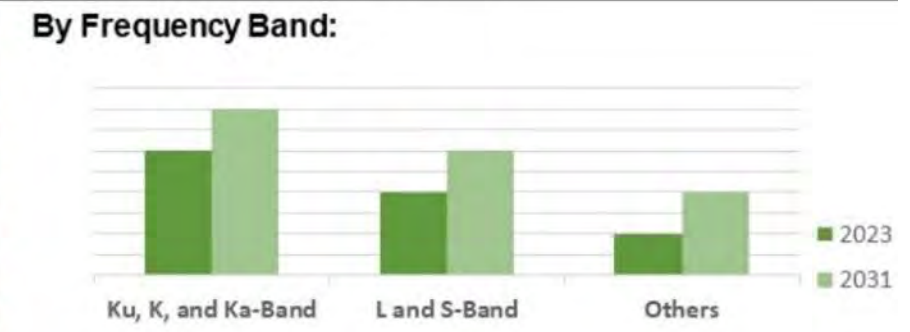
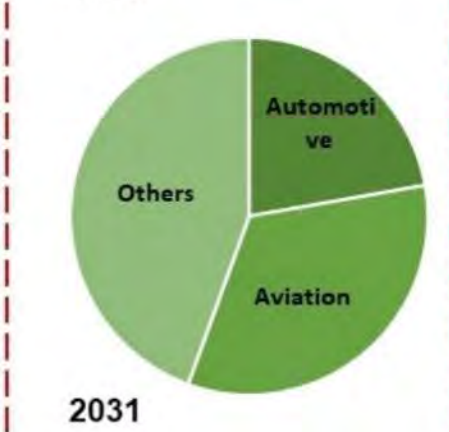
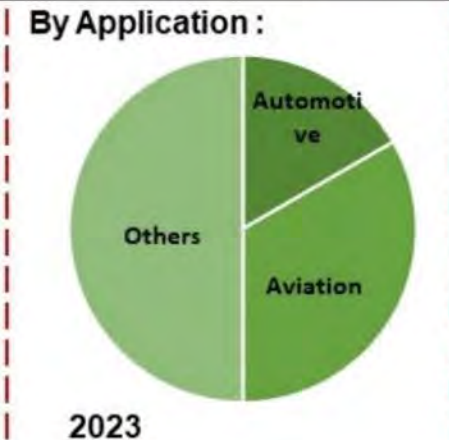
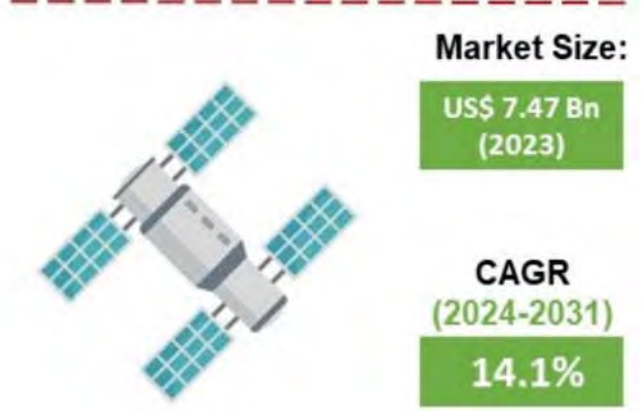

Modular and Scalable Flat Panel Ka Satcom Antennas in Development

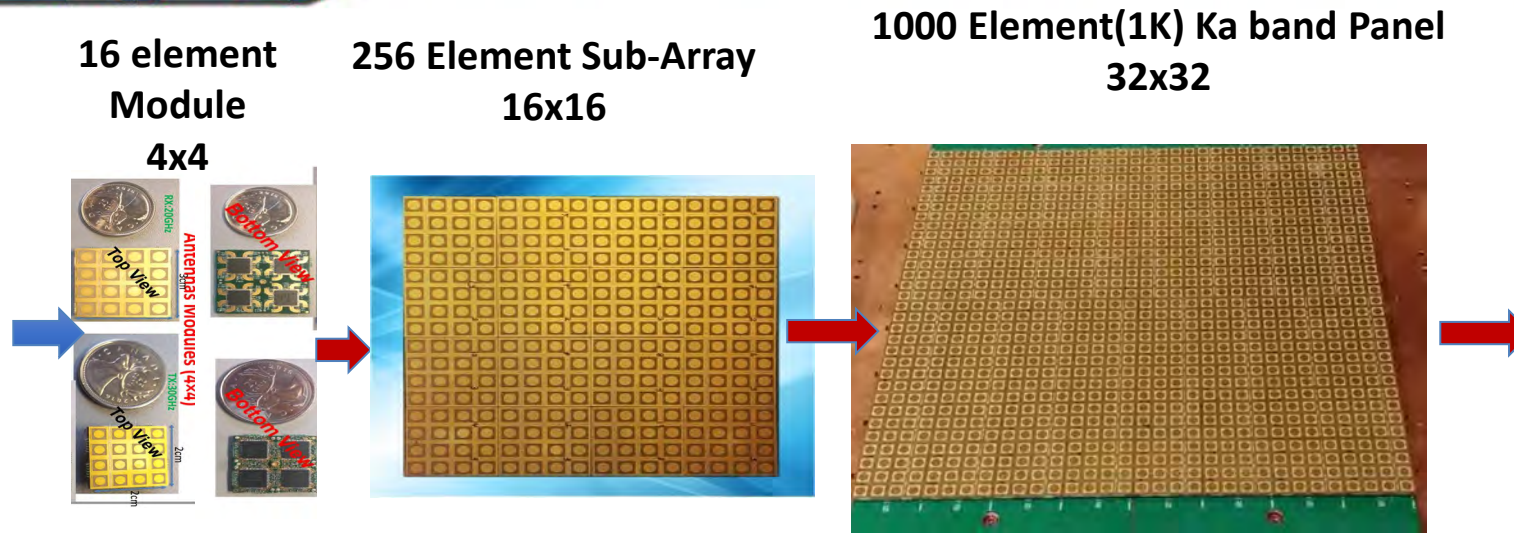

Satellite Ground Terminal (GEO, MEO, LEO)



**Popular Mechanical Scanning
Antenna**

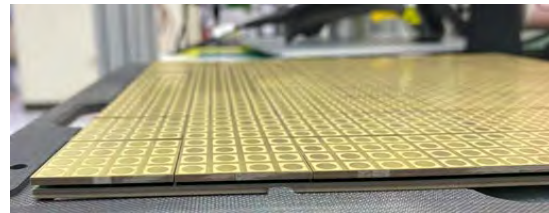
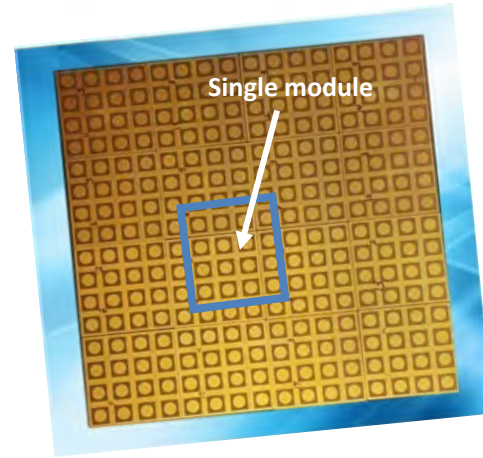

**New Generation Antenna
Flat Electronic Scanning Antenna
under Development by C-COM**

iNetVu® iNmotion ESA Antenna

Supports GEO, LEO, MEO
Multi-Orbit Constellations
Ka-band Frequency: Transmit: 27.5-
30.0 GHz Receive: 17.7-20.2GHz
Electronic Beam Steering and
Tracking
Elevation Angles: 20-90 deg; (70deg
from Boresight) with scan loss up to
5dB
Azimuth Angles: 360 deg Continuous
Polarization: Software switchable,
Linear (H/V) or CP (RH/LH)



NSR's Flat Panel Market Penetration Rate

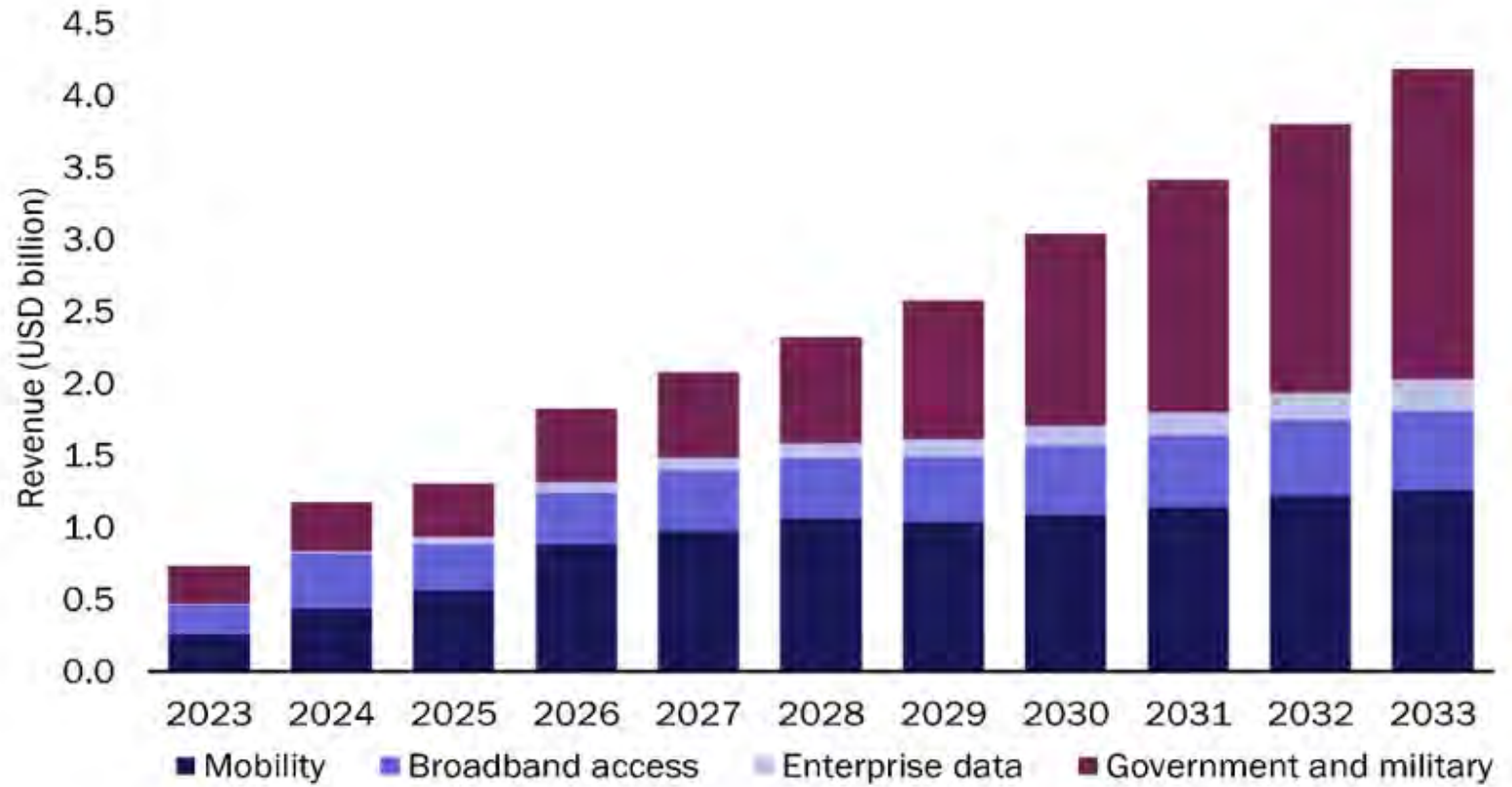

Source: Analysys Mason

Research and Markets Flat Panel Antenna Industry Forecast



Emerging LEO/MEO Constellations and the growing need for Electronic Scanning Ground Terminals

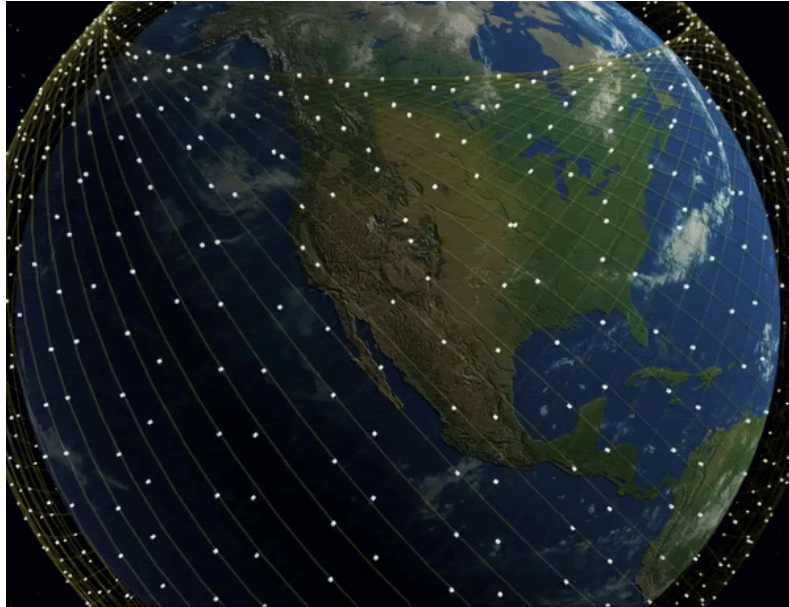

Canada TELESAT Lightspeed Constellation

Broadband LEO/MEO/GEO Satellite Connectivity on the Move

Cars with ESA Antennas

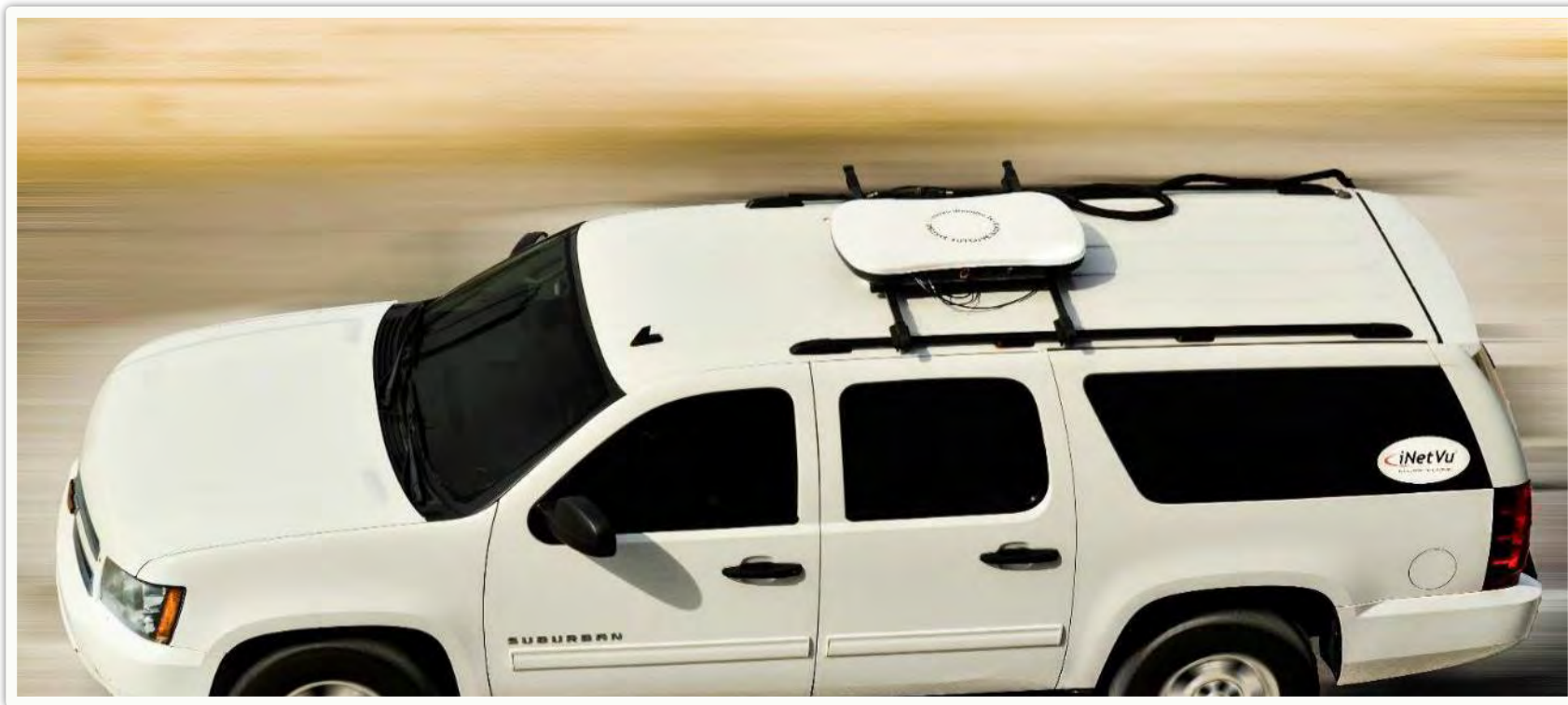

High-Speed Trains with Phased Array Antennas



Simulation of Aircraft with Phased Array Antennas



Integration of Silicon BFICs (a Key Component) into Antenna Modules

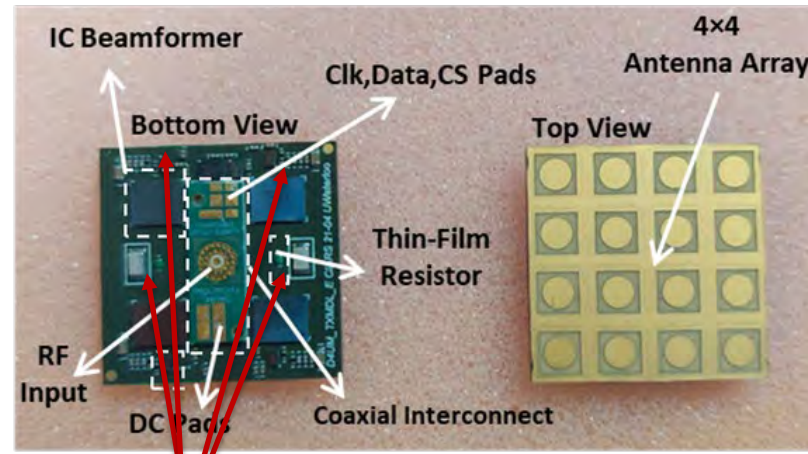
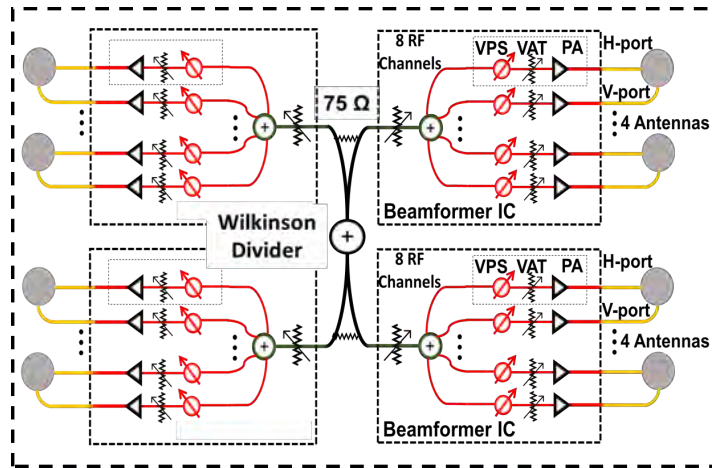

Multi-channel BFICs

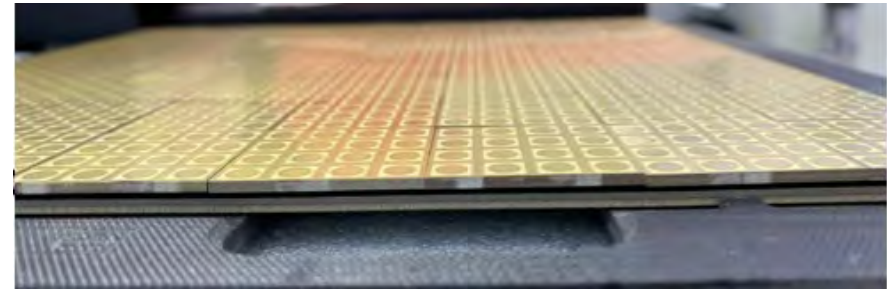

- ❑ TX frequency band : 27.50-31 GHz.
- ❑ RX Frequency band: 17.7-21.2GHz
- ❑ Programmable Polarization : LP (H/V) and CP (RH/LH).

C-COM Ka-band BFIC Evolution

World's Highest Performance, Lowest Power Consumption Satcom BFIC

Significant research and engineering development in developing high performance

Custom Satellite Chip

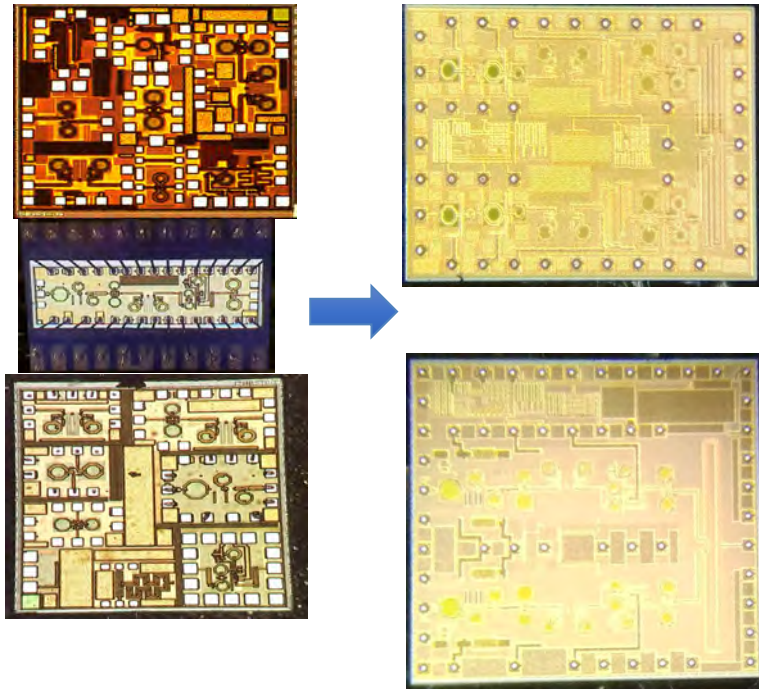

C-COM Multi-Channel Satcom BFIC

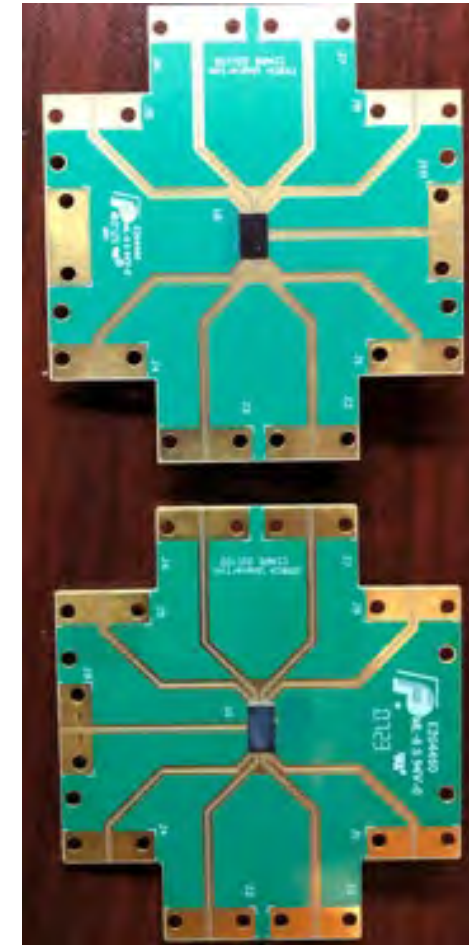

C-COM Ka-band BFIC in Development

World's Highest Performance, Lowest Power Consumption Satcom BFIC

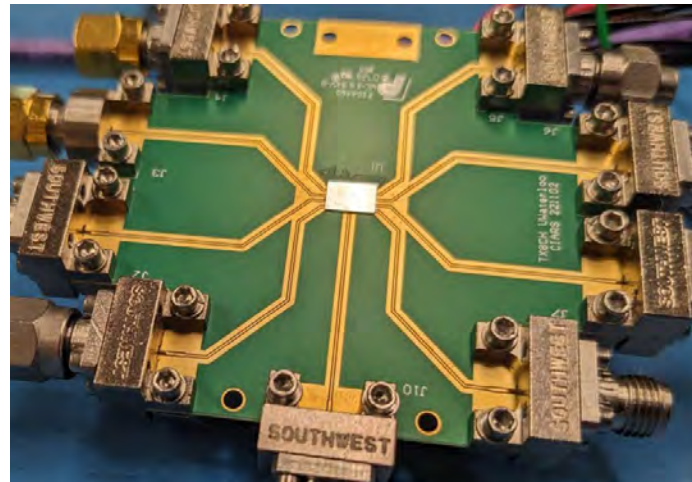
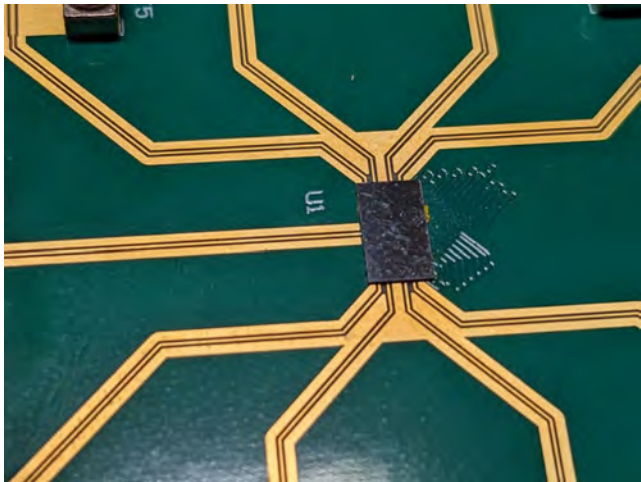
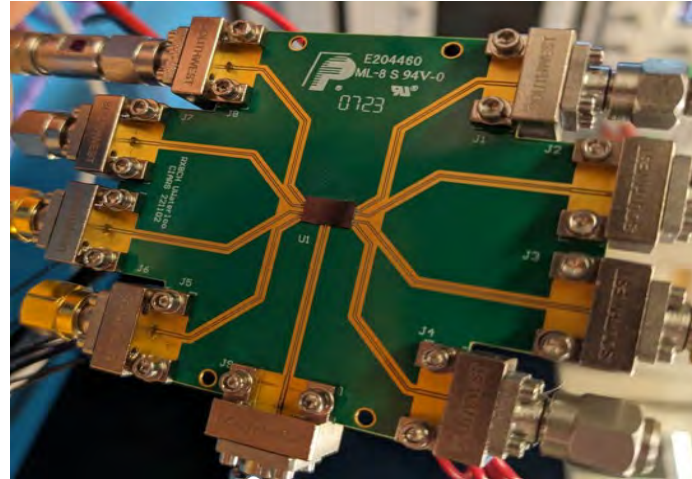
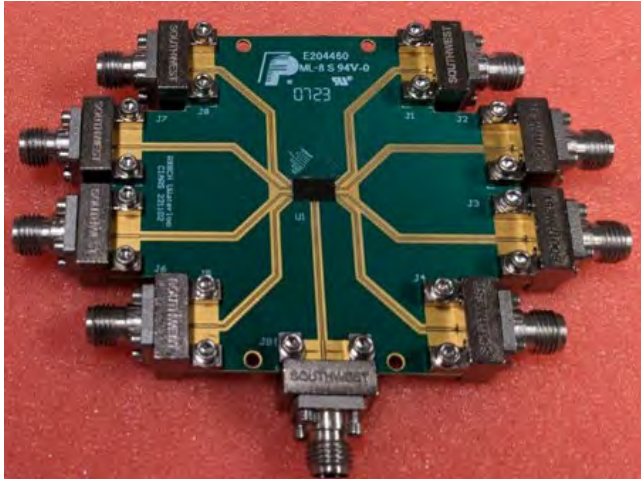

Thank You!



lklein@c-comsat.com

www.c-comsat.com